



**NEXGEN2 ONESIDE BOLT**  
MAGNI COATED



**NEXGEN2**  
ONE SIDE BOLT



ALLFASTENERS NexGen2™ Oneside Bolt Assembly – Patent #10018212 and #9696478 – introduces a streamlined solution for one-sided installation of structural bolts. The NexGen2™ Oneside Bolt assembly has been specifically designed for the tower to provide full structural strength, guaranteed bolt tensioning and superior engagement of the shear sleeve into the shear plane every time.

The NexGen2™ Oneside Bolt Assembly was designed with efficiency in mind. The complete bolt assembly installs in just thirty seconds, saving your company precious time and money.



ICC-ESR 3975

PATENT #9696478, #10018212, #1105396 & #11781579

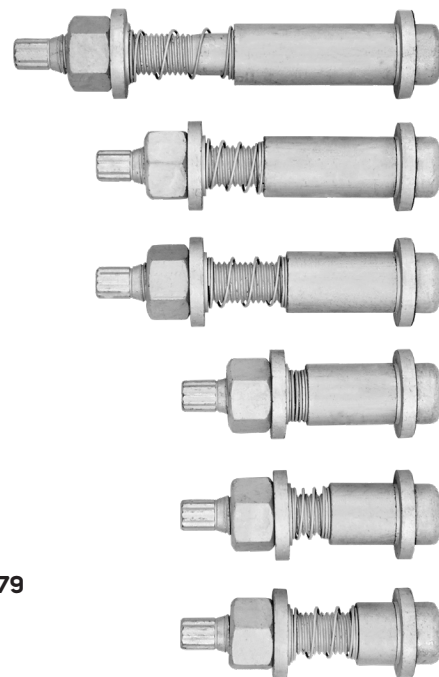

**KEY BENEFITS**

All structural components of the AF NexGen2™ Oneside Bolt Assembly meets their specified material requirements. The NG2 M20 bolt is made from the same material used in the production of ASTM A490. The design capacity of this product depends on the code or standard used by the engineer. The ultimate load capacity of this assembly has been verified per test ASTM F606-14 in tension and ASTM F606-14, NASM1312-20(11) in shear.

AISC steel code has long recognized Oneside Bolts in structural applications. Oneside Bolts features include the elimination for the need and use of nuts while installing. The shank of the fastener is inserted through the connection holes until the head bears out of the outer ply. In some situations, a special tool or wrench is used to open one side, keeping the shank from rotating, but simultaneously turning the threaded part of the assembly.

A wedge or other mechanism on the blind side causes the fixed part of the shank to expand and form a contact with the inside of the HSS. The AF Oneside Bolt Assembly contains a break off mechanism when the fastener is pretensioned.

- Superior structural Strength NexGen2™ M20 Bolt ASTM A490M
- High Tensile Steel Coil Spring
- Shear Sleeve ASTM A519 Grade4140
- Magni Coated Complete Assembly
- Available Lengths 60mm, 95mm, 135mm, 165mm, 250mm
- Guaranteed Tension Every Time
- Clean, Consistent Results
- Less Labor Required, Simple to Install
- Superior Strength & Economical
- Complete Bolt Assembly
- No Guesswork on Tensioning
- No Field Cutting Shear Sleeve
- No Bolt Slipping or Spinning
- Engagement of Shear Sleeve into the Shear Plane Every Time
- Full Shear Capacity of Hole
- Full Tension Capacity of Bolt
- Visual Inspection of correct Tension after Install
- No Lubricant Needed
- Made in the U.S.A.
- Patented Product (#10018212 & #9696478)



## 1.0 RECOGNITION & CERTIFICATIONS

NexGen2™ Oneside Bolt Assembly evaluated in this report shows compliance to the following codes and regulations:

- ICC-ESR 3975
- 2021, 2018, 2015, 2012 and 2009 International Building Code® (IBC)
- 2013 Abu Dhabi International Building Code (ADIBC)

The ADIBC is based on the 2009 IBC. 2009 IBC code sections referenced in this report are the same sections in the ADIBC.

Property Evaluated:

- Structural

## 2.0 USES

AF NexGen2™ Oneside Blind Bolts are designed for connecting structural steel to hollow structural section (HSS) steel members and other structural steel elements where access is difficult or restricted to one side only. NexGen2™ OneSide Blind Bolts are intended for use with rectangular or square HSS members and are recognized for resisting tension and shear loads in bearing-type connections. NexGen2™ OneSide Blind Bolts are alternatives to bolts described in Section J3 of AISC 360, which is referenced in Section 2205.1 of the IBC, for bearing-type connections.

The NexGen2™ OneSide Blind Bolts may be used to resist wind loads, and seismic loads in Seismic Design Categories (SDC) A, B, and C in accordance with Section 1613.2.5 of the 2021 and 2018 IBC, Section 1613.3.5 of the 2015 and 2012 IBC, and Section 1613.5.6 of the 2009 IBC.

## 3.0 DESCRIPTION

### 3.1 GENERAL

AF NexGen2™ OneSide Blind Bolts are assembled from five components, consisting of a steel core bolt, a shear sleeve with steel spring, a hex nut, a solid collar washer and a collapsible split washer. The steel core bolt features a rounded head, threaded shank and tension control spline. The spring sleeve is a steel hollow cylinder with a premounted high tensile strength wire spring. The NexGen2™ OneSide Blind Bolt nominal diameter is 20 mm with lengths of 95, 135, 175 and 250 mm.

### 3.2. MATERIALS

- |  |   |
|--|---|
| <p><b>3.2.1 Core Bolt:</b> The core bolt is manufactured from steel complying with ASTM A490M with a minimum specified <math>F_u</math> of 150,000 psi (1034 MP<sub>a</sub>), a 29mm outer diameter rounded head and a double hex splined end.</p> <p><b>3.2.2 Shear Sleeve with Steel Spring:</b> The shear sleeve is manufactured from steel complying with ASTM A29 (4140) with a minimum specified <math>F_u</math> of 120,00 psi (827 MP<sub>a</sub>). The steel spring is manufactured from wire complying with ASTM A228 with a 0.050 inch diameter. The spring is used to hold the shear sleeve in the correct position.</p> | <p><b>3.2.3 Hex Nut:</b> The hex nut is a prelubricated M20-2.50 heavy hex nut manufactured from steel complying with ASTM A194 2H.</p> <p><b>3.2.4 Solid Collar Washer:</b> The solid collar washer is manufactured from steel complying with 1045 HRC 23-24.</p> <p><b>3.2.5 Collapsible Split Washer:</b> The collapsible split washer is manufactured from steel complying with 1045 HRC 23-24.</p> <p><b>3.2.6 Finish Coating:</b> All NexGen2™ Oneside Bolt components are Magni 554 duplex coated to a minimum thickness of 3 microns.</p> |
|--|---|



## 4.0 DESIGN & INSTALLATION

### 4.1 DESIGN

The NexGen2™ OneSide Blind Bolts are alternatives to bolts described in Section J3 of AISC 360, which is referenced in Section 2205.1 of the IBC, for bearing-type connections. The design of the NexGen2™ OneSide Blind Bolts must comply with this report, Section J3 of AISC 360 and the strength design information for the NexGen2™ OneSide Blind Bolts provided in this report. The load-carrying capacity of the assembly depends on the bolts, the type of steel elements connected (such as HSSs), and their cross sections (thickness). The design strength is limited by the strength of the weakest component in the bolted assembly, which includes the affected elements of members and connecting elements and the bolts. The capacity may be governed by the affected elements and/or connecting elements in the case of thin sections, or the NexGen2™ OneSide Blind Bolt in the case of thick wall sections (or a combination of the two). All limit states must be checked to determine the load-carrying capacity of the assembly. Combined tension and shear loading must comply with the following:

$$\left(\frac{\textit{Tension Demand}}{\textit{Tension Capacity}}\right)^2 + \left(\frac{\textit{Shear Demand}}{\textit{Shear Capacity}}\right)^2 \leq 1.0$$

### 4.2 INSTALLATION

The NexGen2™ OneSide Blind Bolts must be installed in accordance with the details noted in this section, the manufacturer's installation instructions and the approved plans.

1. Holes must be drilled into the steel sections to be connected, ensuring that the resulting holes have the correct diameter and spacing according to the manufacturer's published specifications, and the correct design requirements for the connection, as indicated in the approved plans. Holes must be 30 mm diameter.
2. Burrs in the holes must be removed before insertion of the NexGen2™ OneSide Blind Bolts. Field drilled holes shall be protected with cold-galvanized compound.
3. The structural steel elements to be connected must be positioned adjacent to each other to ensure that the two sections are lined up and bearing against the other without any gaps. Clamps may be used to hold the two steel sections together and prevent formation of gaps.
4. The NexGen2™ OneSide Blind Bolt must be installed in the holes in accordance with Figure 3.
5. Torque is applied until the bolt spline separates from the bolt.
6. The sheared bolt end of the NexGen2™ OneSide Blind Bolt is protected with cold-applied galvanizing compound.

### 4.3 SPECIAL INSPECTION

Special inspection is required in accordance with Sections 1705.1 and 1705.2 of the 2021, 2018, 2015 and 2012 IBC (Sections 1704.3 and 1704.15 of the 2009 IBC). The manufacturer must submit inspection procedures to verify proper installation of the NexGen2™ OneSide Blind Bolts. Where NexGen2™ OneSide Blind Bolts are used for seismic or wind load resistance, special inspection requirements must comply with Sections 1704.3 and 1705 of the 2021, 2018, 2015 and 2012 IBC (Sections 1705, 1706 and 1707 of the 2009 IBC).

### 5.0 CONDITIONS OF USE

The NexGen2™ OneSide Blind Bolts described in this report comply with, or are suitable alternatives to what is specified in, the code noted in Section 1.0 of this report, subject to the following conditions:

- 5.1** Calculations and details showing that the NexGen2™ OneSide Blind Bolts are adequate to resist the applied loads must be submitted to the code official for approval. The connected steel base materials and connecting steel elements also must be adequate to support the applied loads. The calculations and details must be signed and sealed by a registered design professional, when required by the statutes of the jurisdiction in which the project is to be constructed.



# NEXGEN2 ONESIDE BOLT

MAGNI COATED



**5.2 Fire-resistive construction:** Where not otherwise prohibited in the code, NexGen2™ OneSide Blind Bolts are permitted for use with fire-resistance-rated construction provided that at least one of the following conditions is fulfilled:

- The NexGen2™ OneSide Blind Bolts are used to resist wind or seismic forces only.
- NexGen2™ OneSide Blind Bolts that support a fire-resistance-rated envelope or a fire-resistance-rated membrane, are protected by approved fire-resistance-rated materials, or have been evaluated for resistance to fire exposure in accordance with recognized standards.
- The NexGen2™ OneSide Blind Bolts are used to support nonstructural elements.

**5.3 Special inspection** must be provided as specified in Section 4.3 of this report.

**5.4 Use of the NexGen2™ OneSide Blind Bolts** in applications where the applicable code requires slip-critical installation is beyond the scope of this report.

**5.5 Corrosion resistance** of the NexGen2™ OneSide Blind Bolts and connected steel elements is outside the scope of this evaluation.

**5.6 Use of the NexGen2™ OneSide Blind Bolts** is limited to Seismic Design Categories (SDC) A, B, and C.

## 6.0 EVIDENCE SUBMITTED

Data in accordance with the ICC-ES Acceptance Criteria for OneSide Blind Bolts in Structural Steel Connections (AC437), dated June 2022.

## 7.0 IDENTIFICATION

**7.1** The ICC-ES mark of conformity, electronic labeling, or the evaluation report number (ICC-ES ESR-3975) along with the name, registered trademark, or registered logo of the report holder must be included in the product label.

**7.2** In addition, the NexGen2™ OneSide Blind Bolt is identified by a seven-character part number (2NGXXXX). The first three characters (2NG) indicate the product is an Allfasteners NexGen2™ OneSide Blind Bolt, the next two digits denote the diameter and the last two digits indicate the length. Each package of the NexGen2™ OneSide Blind Bolts includes the following information: NexGen2™ OneSide Blind Bolt product nomenclature, quantity, part number, lot number, and an image of the product.

**7.3** The report holder’s contact information is the following:

**ALLFASTENERS USA 959 LAKE ROAD MEDINA, OHIO 44256 (440) 232-6060 [www.allfasteners.com](http://www.allfasteners.com)**

## PARTS

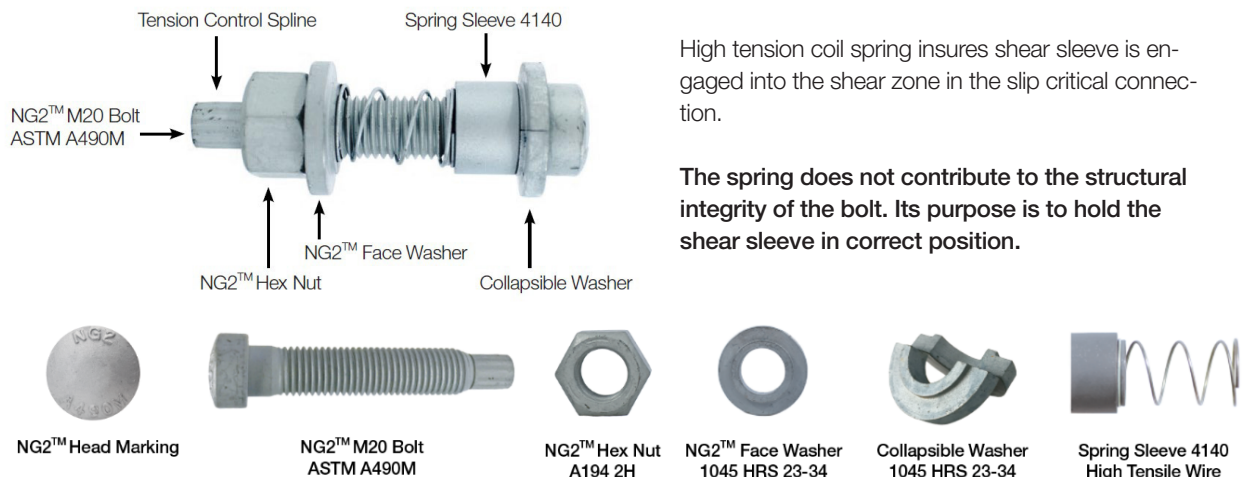

**FIGURE 1—NEXGEN2™ ONESIDE BLIND BOLT**



**PRODUCT INFORMATION**

**TABLE 1 – NEXGEN2™ ONESIDE BLIND BOLT TECHNICAL DATA**

Part Number	DIMENSIONAL INFORMATION				Drill Diameter (mm)	
	Core Bolt Diameter (mm)	Core Bolt Length (mm)	Grip Range (in.)			Sleeve Length (in.)
			Min.	Max.		
2NG2036	20	95	0.9375	1.4375	0.6875	30
2NG2048	20	95	1.4375	1.8750	1.1875	30
2NG2057	20	95	1.8750	2.1250	1.6250	30
2NG2068	20	135	2.1250	2.6875	2.0000	30
2NG2096	20	135	2.6875	3.7500	2.4375	30
2NG2127	20	175	3.7500	5.1875	3.0000	30
2NG2212	20	250	5.0000	8.3125	4.0000	30

For SI: 1 inch = 25.4 mm

\* NOTE: Grip can be increased to 0.1875 - 0.875 with removal of collar. MUST specify this requirement at time of order, otherwise M20x60 will have standard grip range of 0.625-0.875.

**TABLE 2 – NEXGEN2™ LRFD SHEAR DESIGN STRENGTH BASED ON THE EXTERIOR PLY <sup>1,2,3,4,5,6</sup>**

LRFD Bolt Shear Design Strength (kips)						
ASTM A53-35	ASTM A36	ASTM A572-42	ASTM A572-50	ASTM A572-55	ASTM A572-60	ASTM A572-65
38.6	37.3	38.6	41.8	45.0	46.5	46.5

For SI: 1 kip = 4.448 kN

1. LRFD Design Strength based on resistance factor  $\phi = 0.63$ . For ASD Allowable Strength, divide tabulated values by 0.63 and then divide by safety factor  $\Omega = 2.53$ .
2. The shear sleeve must extend into the shear plane a minimum of 0.3125 in. (7.9 mm).
3. The exterior ply thickness must not be less than 0.500 in. (12.7 mm). The interior ply thickness must not be less than 0.1875 in. (4.8 mm).
4. The exterior ply and interior ply material tensile strengths ( $F_u$ ) must not be less than 58 ksi (400 MPa).
5. The distance between centers of bolt holes must not be less than 3.0 in. (76 mm). The distance between the centers of the bolt holes and the end of the steel elements to be connected must not be less than 1.5 in. (38 mm).
6. These design strengths represent the minimum individual bolt capacity for a bolt located within an end connection.



**NEXGEN2 ONESIDE BOLT**  
MAGNI COATED



**TABLE 3—NEXGEN2™ LRFD SHEAR DESIGN STRENGTH BASED ON THE INTERIOR PLY** <sup>1,2,3,4,5,6</sup>

LRFD Bolt Shear Design Strength (kips)							
Interior Ply Thickness, t (in.)	Interior Ply Material Grade						
	ASTM A53-35	ASTM A36	ASTM A572-42	ASTM A572-50	ASTM A572-55	ASTM A572-60	ASTM A572-65
0.1875 (3/16)	18.4	17.7	18.4	19.9	21.4	22.9	24.5
0.2188 (7/32)	21.4	20.7	21.4	23.2	25.	26.8	28.5
0.2500 (1/4)	24.5	23.7	24.5	26.5	28.5	30.6	32.6
0.2813 (9/32)	27.5	26.6	27.5	29.8	32.1	34.4	36.7
0.3125 (5/16)	30.6	29.6	30.6	33.1	35.7	38.2	40.8
0.3438 (11/32)	33.6	32.5	33.6	36.4	39.3	42.1	44.9
0.3750 (3/8)	36.7	35.5	36.7	39.8	42.8	45.9	46.5
0.4063 (13/32)	39.8	38.4	39.8	43.1	46.4	46.5	46.5
0.4375 (7/16)	42.8	41.4	42.8	46.4	46.5	46.5	46.5
0.4688 (15/32)	45.9	44.3	45.9	46.5	46.5	46.5	46.5
≥ 0.5000 (1/2)	46.5	46.5	46.5	46.5	46.5	46.5	46.5

For SI: 1 inch = 25.4 mm; 1 kip = 4.448 kN

1. LRFD Design Strength based on resistance factor  $\phi = 0.63$ . For ASD Allowable Strength, divide tabulated values by 0.63 and then divide by safety factor  $\Omega = 2.53$ .
2. The shear sleeve must extend into the shear plane a minimum of 0.3125 in. (7.9 mm).
3. The exterior ply thickness must not be less than 0.500 in. (12.7 mm). The interior ply thickness must not be less than 0.1875 in.(4.8 mm).
4. The exterior ply and interior ply material tensile strengths ( $F_u$ ) must not be less than 58 ksi (400 MPa).
5. The distance between centers of bolt holes must not be less than 3.0 in. (76 mm). The distance between the centers of the bolt holes and the ends of the steel elements to be connected must not be less than 1.5 in. (38 mm).
6. These design strengths represent the minimum individual bolt capacity for a bolt located within an end connection.

**TABLE 4—NEXGEN2™ LRFD TENSION DESIGN STRENGTH BASED ON THE INTERIOR AND EXTERIOR PLYS—1,2,3,4,5,6**

LRFD Bolt Tension Design Strength (kips)							
Interior Ply Thickness, t (in.)	Ply Material Grade						
							33.8
0.1875 (3/16)							33.8
0.2188 (7/32)					33.8	33.8	33.8
0.2500 (1/4)				33.8	33.8	33.8	33.8
0.2813 (9/32)			33.8	33.8	33.8	33.8	33.8
0.3125 (5/16)	33.8	33.8	33.8	33.8	33.8	33.8	33.8
≥ 0.375 (3/8)	33.8	33.8	33.8	33.8	33.8	33.8	33.8

For SI: 1 inch = 25.4 mm; 1 kip = 4.448 kN

1. LRFD Design Strength is based on a resistance factor  $\phi = 0.63$ . For ASD Allowable Strength, divide tabulated values by 0.63 and then divide by safety factor  $\Omega = 2.53$ .
2. The shear sleeve must extend into the shear plane a minimum of 0.3125 in. (7.9 mm).
3. The exterior ply thickness must not be less than 0.500 in. (12.7 mm). The interior ply thickness must not be less than 0.1875 in.(4.8 mm)
4. The exterior ply and interior ply material tensile strengths ( $F_u$ ) must not be less than 58 ksi (400 MPa).
5. The distance between centers of bolt holes must not be less than 3.0 in. (76 mm). The distance between the centers of the bolt holes and the ends of the steel elements to be connected must not be less than 1.5 in. (38 mm).
6. These design strengths represent the minimum individual bolt capacity for a bolt located within an end connection.



# NEXGEN2 ONESIDE BOLT

MAGNI COATED



## TYPICAL NG2™ BOLT DETAIL



FIGURE 3—NEXGEN2™ ONESIDE BLIND BOLT INSTALLATION INSTRUCTIONS

## TYPICAL NG2™ BOLT DETAIL

### TYPICAL NG2™ BOLT DETAIL: *PRE-TENSION*

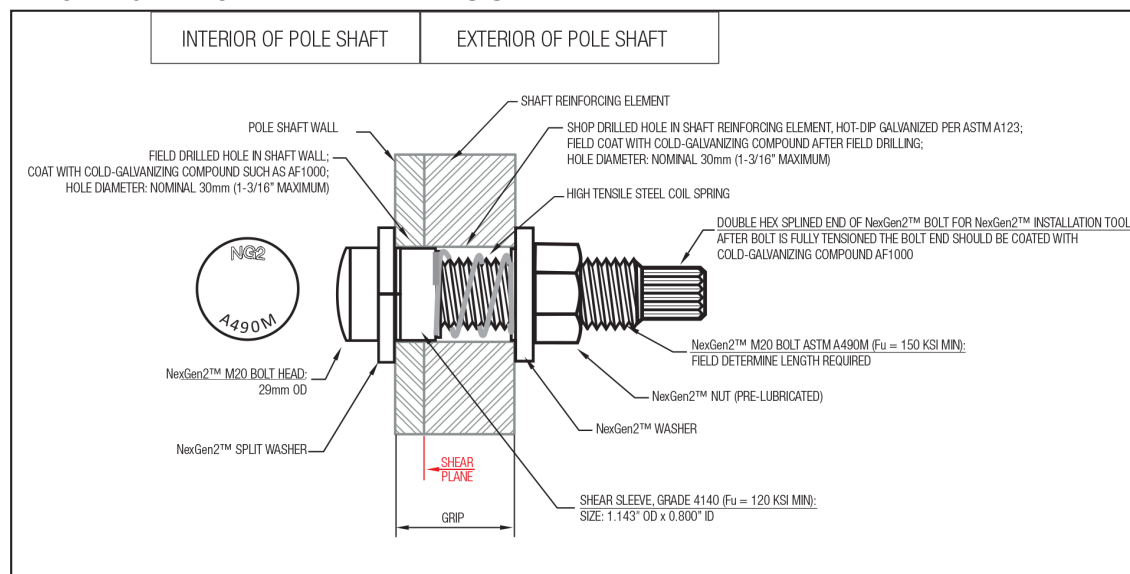

### TYPICAL NG2™ BOLT DETAIL: *POST-TENSION*

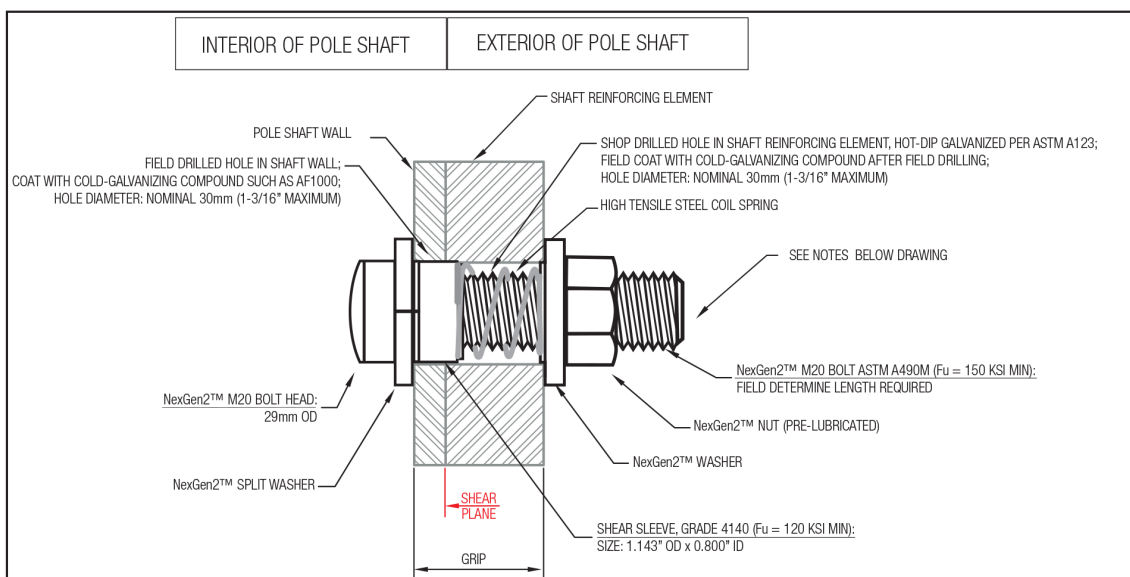



**BOLT TENSIONING TEST**

**Pretension Skimore Test**

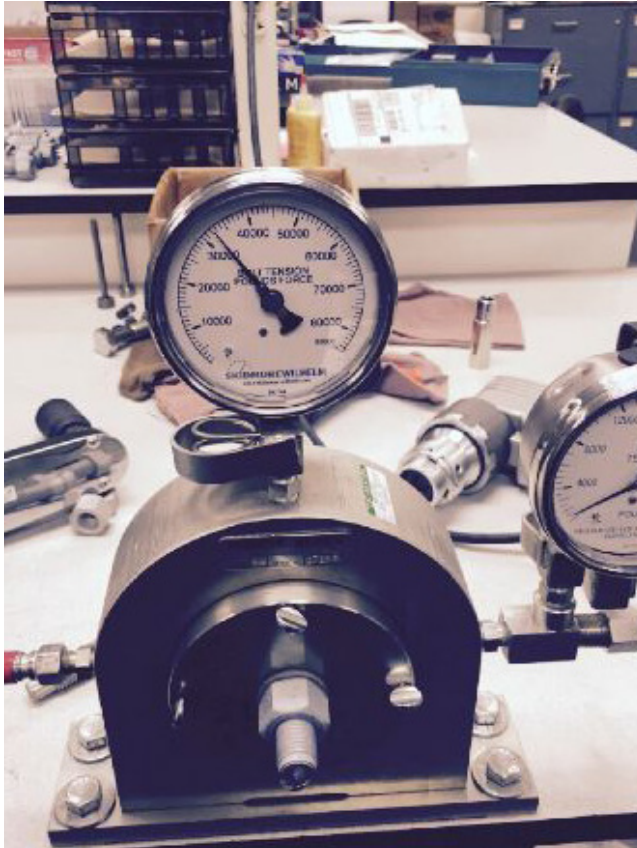

Minimum of 28 kips required per manufacturer specifications

**TEST REPORTS - MTR**



**Product Certificate of Conformance**

<b>AF Lot #:</b> 9861		<b>Customer PO #:</b>				<b>Part #:</b> 2NG2036						
		<b>Test Results</b>										
		<b>Proof Load (Mpa)</b>		<b>Hardness (HRC)</b>			<b>Wedge Tensile Test (psi)</b>					
		<b>Spec</b>		<b>Spec</b>		<b>Sample</b>		<b>Spec</b>		<b>Sample</b>		
<b>Lot Number</b>	<b>Component Part Number</b>	<b>Description</b>		<b>Min</b>	<b>Sample</b>	<b>Min</b>	<b>Max</b>	<b>A</b>	<b>B</b>	<b>Min</b>	<b>A</b>	<b>B</b>
26308	2NG20095A490M	M20 x 95 NexGen2™ Structural Bolt				33	38	Pass	Pass	150000	Pass	Pass
41002	2HHNM2025G2HM	M20-2.50 Heavy Hex Nut Grade 2H		1165	Pass	24	36	Pass	Pass			
794351	14SLSS1116M	11/16" Shear Sleeve				24	33	Pass	Pass			
54179	2NG2SWH	M20 NexGen2™ Collapsible Split Washer				23	34	Pass	Pass			
51974	2NG2CWM	M20 Solid Collar Washer				23	34	Pass	Pass			





**TEST REPORTS**



A DIVISION OF J.T. ADAMS CO., INC.

4520 WILLOW PARKWAY  
CLEVELAND, OHIO 44125  
PHONE (216) 641-3290  
FAX (216) 641-1223  
www.tensile.com

**CERTIFIED TEST REPORT**

Allfasteners  
15401 Commerce Park Drive  
Cleveland OH 44142

Amended Copy: 1-23-18  
Job No.: 1503-20-1173  
Date: 3-20-15  
Cust. PO#: 41875

Description: 6 samples M20 x 2.5 Order Code: 00-7760-00 Bolts

Spec: ASTM A490M-14a

**TEST RESULTS**

ID#	<u>Axial Tensile, lbs</u>
Requirements (Min.):	56,900-65,636
1	62,000
2	62,000
3	62,000

Test Method: ASTM F606-14

ID#	<u>Single Shear, lbs</u>
1	76,500
2	80,500
3	77,500

Test Method: ASTM F606-14, NASM 1312-20 (11)

Authorized Agent





## A490M TEST REPORT

ID#	Axial Tensile, lbs
Requirements (Min.):	56,900-65,636



62,000



62,000



62,000

Test Method: ASTM F606-11a

ID#	Single Shear, lbs
-----	-------------------



76,500



80,500



77,500

Test Method: NASM 1312-20 (11)

**SHEAR & TENSILE STRENGTH****Properties:**

NexGen2™ M20 Bolt:

Material Grade: ASTM A490M

Nominal Bolt Diameter,  $d_b$ : 0.787 inNominal Bolt Area,  $A_{bolt}$ : 0.487 in<sup>2</sup>Net Bolt Area,  $A_n$ : 0.379 in<sup>2</sup>

Shear Sleeve:

Material Grade: ASTM A519 Grade 4140 ( $F_u=120$  ksi

min.)

Outside Diameter: 1.143 in

Inside Diameter: 0.800 in

Shear Sleeve Area,  $A_s$ : 0.523 in<sup>2</sup>**Allowable Strengths in accordance with ANSI/TIA/EIA-222-F:**

Note: All values below do not include the 4/3 increase allowed for transient load combinations

**Allowable Tensile Strength:**

$$R_{at} = F_t A_b$$

$$F_t = 54 \text{ ksi} \quad (\text{Table J3.2})$$

$$A_{bolt} = 0.487 \text{ in}^2$$

$$R_{at} = (54)(0.487) = 26.3 \text{ kips}$$

**26.3 kips – Tensile Capacity****Allowable Shear Strength – Threads Included ('N'):**

$$R_{av} = F_v A_b$$

$$F_{v\_bolt} = 28 \text{ ksi} \quad (\text{Table J3.2})$$

$$F_{v\_sleeve} = 30 \text{ ksi} \quad (\text{Table J3.2})$$

$$A_{bolt} = 0.487 \text{ in}^2$$

$$A_s = 0.523 \text{ in}^2$$

$$R_{av} = (28)(0.487) + (30)(0.523) = 29.3 \text{ kips}$$

**29.3 kips – 'N' Shear Capacity****Allowable Shear Strength – Threads Excluded ('X'):**

$$R_{av} = F_v A_b$$

$$F_{v\_bolt} = 40 \text{ ksi}$$

$$F_{v\_sleeve} = 30 \text{ ksi} \quad (\text{Table J3.2})$$

$$A_{bolt} = 0.487 \text{ in}^2$$

$$A_s = 0.523 \text{ in}^2$$

$$R_{av} = (40)(0.487) + (30)(0.523) = 35.2 \text{ kips}$$

**35.2 kips – 'X' Shear Capacity****Design Strengths in accordance with ANSI/TIA-222-G:****Design Tensile Strength:**

$$\phi R_{nt} = \phi F_{ub} A_n \quad (\text{Section 4.9.6.1})$$

$$\phi = 0.75$$

$$F_{ub} = 150 \text{ ksi}$$

$$A_n = 0.379 \text{ in}^2$$

$$\phi R_{nt} = (0.75)(150)(0.379) = 42.6 \text{ kips}$$

**42.6 kips – Tensile Capacity****Design Shear Strength – Threads Included ('N'):**

$$\phi R_n = \phi 0.45 F_{ub} A_b \quad (\text{Section 4.9.6.3})$$

$$\phi = 0.75$$

$$F_{ub} = 150 \text{ ksi}$$

$$F_{us} = 120 \text{ ksi}$$

$$A_{bolt} = 0.487 \text{ in}^2$$

$$A_s = 0.523 \text{ in}^2$$

$$\phi R_n = (0.75)(150*0.45*0.487 + 120*0.55*0.523) = 50.5 \text{ kips}$$

**50.5 kips – 'N' Shear Capacity****Design Shear Strength – Threads Excluded ('X'):**

$$\phi R_n = \phi 0.55 F_{ub} A_b \quad (\text{Section 4.9.6.3})$$

$$\phi = 0.75$$

$$F_{ub} = 150 \text{ ksi}$$

$$F_{us} = 120 \text{ ksi}$$

$$A_{bolt} = 0.487 \text{ in}^2$$

$$A_s = 0.523 \text{ in}^2$$

$$\phi R_n = (0.75)(150*0.55*0.487 + 120*0.55*0.523) = 56.0 \text{ kips}$$

**56.0 kips – 'X' Shear Capacity**

**SHEAR & TENSILE STRENGTH (CONT'D)****Design Strengths in accordance with ANSI/TIA-222-H:****Design Tensile Strength:**

$$\phi R_{nt} = \phi F_{ub} A_n \quad (\text{Section 4.9.6.1})$$

$$\phi = 0.75$$

$$F_{ub} = 150 \text{ ksi}$$

$$A_n = 0.379 \text{ in}^2$$

$$\phi R_n = (0.75)(150)(0.379) = 42.6 \text{ kips}$$

**42.6 kips – Tensile Capacity****Design Shear Strength – Threads Included ('N'):**

$$\phi R_n = \phi 0.45 F_{ub} A_b \quad (\text{Section 4.9.6.3})$$

$$\phi = 0.75$$

$$F_{ub} = 150 \text{ ksi}$$

$$F_{us} = 120 \text{ ksi}$$

$$A_{bolt} = 0.487 \text{ in}^2$$

$$A_s = 0.523 \text{ in}^2$$

$$\phi R_n = (0.75)(150*0.45*0.487 + 120*0.563*0.523) = 51.2 \text{ kips}$$

**51.2 kips – 'N' Shear Capacity****Design Shear Strength – Threads Excluded ('X'):**

$$\phi R_n = \phi 0.563 F_{ub} A_b \quad (\text{Section 4.9.6.3})$$

$$\phi = 0.75$$

$$F_{ub} = 150 \text{ ksi}$$

$$F_{us} = 120 \text{ ksi}$$

$$A_{bolt} = 0.487 \text{ in}^2$$

$$A_s = 0.523 \text{ in}^2$$

$$\phi R_n = (0.75)(150*0.563*0.487 + 120*0.563*0.523) = 57.3 \text{ kips}$$

**57.3 kips – 'X' Shear Capacity****Design Strengths in accordance with AISC 360-05 (13<sup>th</sup> Edition):****Design Tensile Strength:**

$$\phi R_n = \phi F_n A_b \quad (\text{Equation: J3-1})$$

$$\phi = 0.75$$

$$F_n = 113 \text{ ksi} \quad (\text{Table J3.2})$$

$$A_b = A_{bolt} = 0.487 \text{ in}^2$$

$$\phi R_n = (0.75)(113)(0.487) = 41.3 \text{ kips}$$

**41.3 kips – Tensile Capacity****Design Shear Strength – Threads Included ('N'):**

$$\phi R_n = \phi F_n A_b \quad (\text{Equation: J3-1})$$

$$\phi = 0.75$$

$$F_{n\_bolt} = 60 \text{ ksi} \quad (\text{Table J3.2})$$

$$F_{n\_sleeve} = 60 \text{ ksi} \quad (\text{Table J3.2})$$

$$A_{bolt} = 0.487 \text{ in}^2$$

$$A_s = 0.523 \text{ in}^2$$

$$\phi R_n = (0.75)(0.487*60 + 0.523*60) = 45.5 \text{ kips}$$

**45.5 kips – 'N' Shear Capacity****Design Shear Strength – Threads Excluded ('X'):**

$$\phi R_n = \phi F_n A_b \quad (\text{Equation: J3-1})$$

$$\phi = 0.75$$

$$F_{n\_bolt} = 75 \text{ ksi} \quad (\text{Table J3.2})$$

$$F_{n\_sleeve} = 60 \text{ ksi} \quad (\text{Table J3.2})$$

$$A_{bolt} = 0.487 \text{ in}^2$$

$$A_s = 0.523 \text{ in}^2$$

$$\phi R_n = (0.75)(75*0.487 + 60*0.523) = 50.9 \text{ kips}$$

**50.9 kips – 'X' Shear Capacity**



**SHEAR & TENSILE STRENGTH (CONT'D)**

**Design Strengths in accordance with AISC 360-10 (14<sup>th</sup> Edition):**

**Design Tensile Strength:**

$\phi R_n = \phi F_n A_b$  (Equation: J3-1)

$\phi = 0.75$

$F_n = 113 \text{ ksi}$  (Table J3.2)

$A_b = A_{bolt} = 0.487 \text{ in}^2$

$\phi R_n = (0.75)(113)(0.487) = 41.3 \text{ kips}$

**41.3 kips – Tensile Capacity**

**Design Shear Strength – Threads Included ('N'):**

$\phi R_n = \phi F_n A_b$  (Equation: J3-1)

$\phi = 0.75$

$F_{n\_bolt} = 68 \text{ ksi}$  (Table J3.2)

$F_{n\_sleeve} = 68 \text{ ksi}$  (Table J3.2)

$A_{bolt} = 0.487 \text{ in}^2$

$A_s = 0.523 \text{ in}^2$

$\phi R_n = (0.75)(68 \cdot 0.487 + 68 \cdot 0.523) = 51.5 \text{ kips}$

**51.5 kips – 'N' Shear Capacity**

**Design Shear Strength – Threads Excluded ('X'):**

$\phi R_n = \phi F_n A_b$  (Equation: J3-1)

$\phi = 0.75$

$F_{n\_bolt} = 84 \text{ ksi}$  (Table J3.2)

$F_{n\_sleeve} = 68 \text{ ksi}$  (Table J3.2)

$A_{bolt} = 0.487 \text{ in}^2$

$A_s = 0.523 \text{ in}^2$

$\phi R_n = (0.75)(84 \cdot 0.487 + 68 \cdot 0.523) = 57.4 \text{ kips}$

**57.4 kips – 'X' Shear Capacity**

**NG2™ LRFD SHEAR DESIGN STRENGTH BASED ON THE EXTERIOR PLY**

LRFD Bolt Shear Design Strength (kips)						
ASTM A53-35	ASTM A36	ASTM A572-42	ASTM A572-5	ASTM A572-55	ASTM A572-60	ASTM A527-65
38.6	37.3	38.6	40.6	40.6	40.6	40.6

For SI: 1 kip = 4.448 kN

1. LRFD Design Strength based in resistance factor  $\phi = 0.55$ . For ASD Allowable Strength, divide tabulated values by 0.55 and then divide by safety factor  $\Omega = 2.91$ .
2. The shear sleeve must extend into the shear plane a minimum of 0.3125 in. (7.9 mm).
3. The exterior ply thickness must not be less than 0.500 in. (12.7 mm). The interior ply thickness must not be less than 0.1875 in. (4.8 mm).
4. The exterior and interior ply material tensile strength ( $F_u$ ) must not be less than 58ksi (400 MPA).
5. The distance between centers of the bolt holes must be less than 3.0 in. (76 mm). The distance between the centers of the bolt hole and the end of the steel elements to be connected must not be less than 1.5 in. (38 mm).
6. These design strengths represent the minimum individual bolt capacity for a bolt location within an end connection.

**NG2™ LRFD SHEAR DESIGN STRENGTH BASED ON THE INTERIOR PLY**

LRFD Bolt Shear Design Strength (kips)							
Interior Ply Thickness, t (in.)	Interior Ply Material Grade						
	ASTM A53-35	ASTM A36	ASTM A572-42	ASTM A572-50	ASTM A572-55	ASTM A572-60	ASTM A572-65
0.1875 (3/16)	18.4	17.7	18.4	19.9	21.4	22.9	24.5
0.2188 (7/32)	21.4	20.7	21.4	23.2	25.0	26.8	28.5
0.2500 (1/4)	24.5	23.7	24.5	26.5	28.5	30.6	32.6
0.2813 (9/32)	27.5	26.6	27.5	29.8	32.1	34.4	36.7
0.3125 (5/16)	30.6	29.6	30.6	33.1	35.7	38.2	40.6
0.3438 (11/32)	33.6	32.5	33.6	36.4	39.3	40.6	40.6
0.3750 (3/8)	36.7	35.5	36.7	39.8	40.6	40.6	40.6
0.4063 (13/32)	39.8	38.4	39.8	40.6	40.6	40.6	40.6
0.4375 (7/16)	40.6	40.6	40.6	40.6	40.6	40.6	40.6
0.4688 (15/32)	40.6	40.6	40.6	40.6	40.6	40.6	40.6
≥ 0.5000 (1/2)	40.6	40.6	40.6	40.6	40.6	40.6	40.6

For SI: 1 inch = 25.4 mm; 1 kip = 4.448kN

1. LRFD Design Strength based in resistance factor  $\phi = 0.55$ . For ASD Allowable Strength, divide tabulated values by 0.55 and then divide by safety factor  $\Omega = 2.91$ .
2. The shear sleeve must extend into the shear plane a minimum of 0.3125 in. (7.9 mm).
3. The exterior ply thickness must not be less than 0.500 in. (12.7 mm). The interior ply thickness must not be less than 0.1875 in. (4.8 mm).
4. The exterior and interior ply material tensile strength ( $F_u$ ) must not be less than 58ksi (400 MPA).
5. The distance between centers of the bolt holes must be less than 3.0 in. (76 mm). The distance between the centers of the bolt hole and the end of the steel elements to be connected must not be less than 1.5 in. (38 mm).
6. These design strengths represent the minimum individual bolt capacity for a bolt location within an end connection.



**NG2™ LRFD SHEAR DESIGN STRENGTH BASED ON THE EXTERIOR & INTERIOR PLIES**

LRFD Bolt Shear Design Strength (kips)							
Interior Ply Thickness, t (in.)	Ply Material Grade						
	ASTM A53-35	ASTM A36	ASTM A572-42	ASTM A572-50	ASTM A572-55	ASTM A572-60	ASTM A572-65
0.1875 (3/16)	20.5	21.1	24.6	28.6	30.8	31.1	31.1
0.2188 (7/32)	24.0	24.6	28.7	31.1	31.1	31.1	31.1
0.2500 (1/4)	27.4	28.2	31.1	31.1	31.1	31.1	31.1
0.2813 (9/32)	30.8	31.1	31.1	31.1	31.1	31.1	31.1
0.3125 (5/16)	31.1	31.1	31.1	31.1	31.1	31.1	31.1
≥ 0.3750 (3/8)	31.1	31.1	31.1	31.1	31.1	31.1	31.1

For SI: 1 inch = 25.4 mm; 1 kip = 4.448kN

1. LRFD Design Strength based in resistance factor  $\phi = 0.55$ . For ASD Allowable Strength, divide tabulated values by 0.55 and then divide by safety factor  $\Omega = 2.91$ .
2. The shear sleeve must extend into the shear plane a minimum of 0.3125 in. (7.9 mm).
3. The exterior ply thickness must not be less than 0.500 in. (12.7 mm). The interior ply thickness must not be less than 0.1875 in. (4.8 mm).
4. The exterior and interior ply material tensile strength ( $F_u$ ) must not be less than 58ksi (400 MPA).
5. The distance between centers of the bolt holes must be less than 3.0 in. (76 mm). The distance between the centers of the bolt hole and the end of the steel elements to be connected must not be less than 1.5 in. (38 mm).
6. These design strengths represent the minimum individual bolt capacity for a bolt location within an end connection.

**TENSION & SHEAR STRENGTH SUMMARY**

DESIGN STANDARD		ALLOWABLE STRENGTH (KIPS) W/O 4/3 INCREASE			DESIGN STRENGTH (KIPS)	
		TIA-F	TIA-G	TIA-H	AISC 360-05	AISC 360-10
TENSILE STRENGTH		26.3	42.6	42.6	41.3	41.3
SHEAR STRENGTH	N	29.3	50.5	51.2	45.5	51.5
	X	35.2	56.0	57.3	50.9	57.4
PRETENSION/CLAMP FORCE		32				

Structural calculations prepared by Ryan J. Rimmele, PE, SE and Tower Engineering Professionals

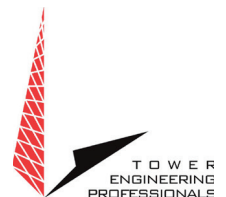



## ACCESSORIES

M20 NexGen2™ Extended Range Shear Wrench	9NG2-22
M20 Outer Socket Extension for NexGen2™ Extended Range Shear Wrench	13NG2-EXT
NexGen2™ Installation Tool	13NG2IT



9NG2-22



13NG2-EXT



13NG2IT

Additional TDS and Information Sheets available for AF Shear Wrench and AF Extended Shear Wrench.

## INSTALLATION

Online installation videos, On-site demos and training available for NexGen2™ Oneside Bolt Assembly. Ask a sales representative today.



Scan the QR Code to Watch the NexGen2 Install Video!

Step-by-step instructions located on next page of NexGen2™ TDS





# NEXGEN2 ONESIDE BOLT

MAGNI COATED



ICC ESR-3975

## INSTALLATION (CONT'D)

### PRE-INSTALL BOLT ON INSTALL TOOL:



1 Thread the installation tool tip into the splined end of the bolt.



2 Remove the nut, the face washer and the spring shear sleeve and slide along the handle of the tool.



3 Move the collapsible washer to the correct location on the tool and fold in place.

### INSTALLATION:



1 Install the bolt into the hole followed by the collapsible washer.

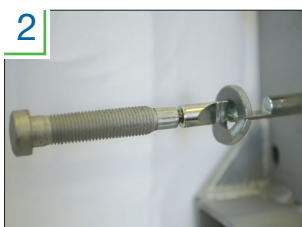

2 Rotate the tool 180°.



3 Pulling back, rock the tool side-to-side to engage the collapsible washer.

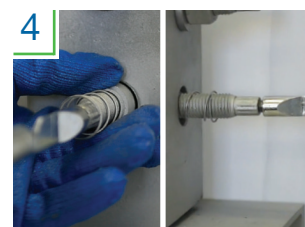

4 Engage the spring shear sleeve into the shear plane.

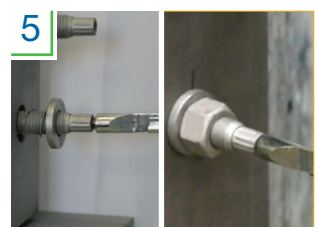

5 Slide the face washer forward and move the nut up to fasten to the bolt. Tighten the nut snug tight at this point.



6 Remove the tool by unscrewing it from bolt (counterclockwise).

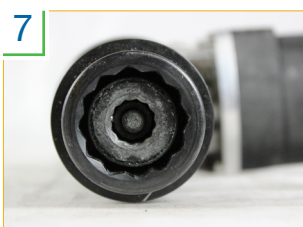

7 Using the shear wrench engage the outer socket with the splined end of the bolt. Press the trigger until correct tension has been achieved (the bolt spline separates from the bolt).



8 Press the small trigger on the shear wrench to eject the bolt spline. The application is now complete.





# NEXGEN2 ONESIDE BOLT

MAGNI COATED



## ORDERING INFORMATION

Part No.	Bolt Length (mm)	Grip Range	Sleeve Length (in)		
2NG2060	M20 x 60	0.625 min.	N/A	24	1440
2NG2032	M20 x 75	0.625 - 1.375	0.5	24	1440
2NG2036	M20 x 95	0.9375 - 1.4375	0.6875	24	1440
2NG2048	M20 x 95	1.4375 - 1.875	1.1875	24	1440
2NG2057	M20 x 95	1.875 - 2.125	1.625	24	1440
2NG2068	M20 x 135	2.125 - 2.6875	1.75	24	1440
2NG2096	M20 x 135	2.6875 - 3.75	2.4375	24	1440
2NG2127	M20 x 175	3.75 - 5.125	3.47	16	1440
2NG2212	M20 x 250	5 - 8.3125	4	10	1440

## DISCLAIMER

IMPORTANT: Information, specifications, procedures and recommendations provided (“information”) are based on our experience and we believe this to be accurate. No representation, guarantee or warranty is made as to the accuracy or completeness of the information or that use of the product will avoid losses or damages or give desired results. It is purchaser’s sole responsibility to test and determine the suitability of any product for the intended use. Tests should be repeated if materials or conditions change in any way. No employee, distributor or agent has any right to change these facts and offer a guarantee of performance.

NOTE TO USER: by ordering/receiving product you accept the ALLFASTENERS General Terms and Conditions of Sale applicable in the region. Please request a copy if you have not received these. These Terms and Conditions contain disclaimers of implied warranties (including but not limited to disclaiming warranties of fitness for a particular purpose) and limits of liability.



## ESR-3975 LABC AND LARC SUPPLEMENT

### 1.0 Report Purpose & Scope

The purpose of this evaluation report supplement is to indicate that NexGen2 OneSide Blind Bolts, described in ICC-ES evaluation report ESR 3975, have also been evaluated for compliance with the codes noted below as adopted by the Los Angeles Department of Building and Safety (LADBS)

#### Applicable Code Editions:

- 2023 City of Los Angeles Building Code (LABC)

## 2.0 CONCLUSIONS

The NexGen2 OneSide Blind Bolts, described in Sections 2.0 through 7.0 of the evaluation report ESR-3975, comply with LABC Chapter 22 and are subject to the conditions of use described in this supplement.

## 3.0 CONDITIONS OF USE

The NexGen2 OneSide Blind Bolts described in this evaluation report supplement must comply with all the following conditions:

- All applicable sections in the evaluation report ESR-3975
- The design, installation, conditions, of use and identification of the NexGen2 OneSide Blind Bolts are in accordance with the 2021 International Building Code (IBC) provisions noted in the evaluation report ESR-3975.
- The design, installation and inspection are in accordance with additional requirements of LABC Chapters 16, 17 and 22, as applicable.

This supplement expires concurrently with the evaluation report, Reissued September 2023



## ESR-3975 CBC SUPPLEMENT

### 1.0 REPORT PURPOSE & SCOPE

The purpose of this evaluation report supplement is to indicate that NexGen2 OneSide Blind Bolts described in ICC-ES evaluation report ESR-3975, have also been evaluated for compliance with the codes noted below:

**Applicable Code Editions:**

- 2022 California Building Code (CBC)

For evaluation of applicable chapters adopted by the California Office of Statewide Health Planning and Development (OSHPD) AKA: California Department of Health Care Access and Information (HCAI) and the Division of the State Architect (DSA), see Sections 2.1.1 and 2.1.2 below.

### 2.0 CONCLUSIONS

- 2.1 CBC:** The NexGen2 OneSide Blind Bolts, described in Sections 2.0 through 7.0 of the evaluation report ESR-3975, comply with CBC Chapter 22, provided the design and installation are in accordance with the 2021 International Building Code (IBC), provisions noted in the evaluation report, and the additional inspection requirements of the CBC Chapters 16, 17 and 22, as applicable.
- 2.1.1 OSHPD:** The applicable OSHPD Sections and Chapters of the CBC are beyond the scope of this supplement.
- 2.1.2 DSA:** The applicable DSA Sections and Chapters of the CBC are beyond the scope of this supplement.

The supplement expires concurrently with the evaluation report, reissued September 2023.